

Maximum Rating Tables

Size 830 • GR & EL Series



Style B

Style H



Size 830

Ratio	nput RPM	Output RPM	nput HP	Output HP	Output Torque (lb in)	Left Hand Catalog No	Right Hand Catalog No	Double Extension Catalog No	Hollow Output Catalog No *
5	2500	500	10 661	10 091	1272	8300001	8300013	8300025	8300501.XX
	1750	350	9 093	8 573	1544				
	1170	234	7 434	6 966	1876				
	100	20	1 177	0 928	2925				
7.5	2500	333	8 178	7 669	1450	8300002	8300014	8300026	8300502.XX
	1750	233	6 879	6 421	1734				
	1170	156	5 668	5 251	2122				
	100	13	0 898	0 683	3228				
10	2500	250	7 293	6 745	1701	8300003	8300015	8300027	8300503.XX
	1750	175	6 151	5 655	2037				
	1170	117	4 989	4 541	2446				
	100	10	0 799	0 567	3573				
15	2500	166	5 734	5 149	1947	8300004	8300016	8300028	8300504.XX
	1750	116	4 843	4 311	2329				
	1170	78	3 903	3 426	2768				
	100	6 7	0 663	0 418	3949				
20	2500	125	4 662	4 067	2051	8300005	8300017	8300029	8300505.XX
	1750	87	3 947	3 407	2454				
	1170	58	3 198	2 713	2923				
	100	5 0	0 579	0 332	4189				
25	2500	100	3 957	3 355	2114	8300006	8300018	8300030	8300506.XX
	1750	70	3 355	2 807	2527				
	1170	46	2 713	2 223	2993				
	100	4 0	0 519	0 269	4238				
30	2500	83	3 389	2 787	2108	8300007	8300019	8300031	8300507.XX
	1750	58	2 879	2 332	2519				
	1170	39	2 335	1 845	2982				
	100	3 3	0 472	0 223	4217				
40	2500	62	2 639	2 054	2071	8300008	8300020	8300032	8300508.XX
	1750	43	2 251	1 720	2477				
	1170	29	1 843	1 366	2944				
	100	2 5	0 407	0 167	4200				
50	2500	50	2 238	1 654	2084	8300009	8300021	8300033	8300509.XX
	1750	35	1 915	1 383	2490				
	1170	23	1 569	1 094	2945				
	100	2 0	0 372	0 132	4156				
60	2500	41	1 907	1 336	2020	8300010	8300022	8300034	8300510.XX
	1750	29	1 637	1 117	2413				
	1170	19	1 348	0 883	2854				
	100	1 7	0 341	0 106	4026				
80	2500	31	0 972	0 671	1352	8300011	8300023	8300035	8300511.XX
	1750	21	0 895	0 585	1684				
	1170	14	0 757	0 463	1996				
	100	1 3	0 126	0 054	2731				
100	2500	25	0 656	0 424	1069	8300012	8300024	8300036	8300512.XX
	1750	17	0 603	0 367	1321				
	1170	11	0 511	0 289	1554				
	100	1 0	0 087	0 033	2100				

How To Build a Part Number For Size GR830 & EL830

1. Select partial catalog number from the selection table
2. Replace leading “_” with series code (GR, EL)
3. For hollow output, replace “XX” suffix with bore code (see next page for codes)

Example:

Grove Gear IRONMAN, style B, 5:1 ratio, left hand output
 GR-B830-5-L
 GR8300001

Single Reduction
Worm Gear Reducers

Double Reduction
Worm - Worm Gear Reducers

Double Reduction
Helical - Worm Gear Reducers

WASHGUARD® Reducers
and GEAR+MOTOR™

Ratio Multipliers

Accessories and
Additional Capabilities

Single Reduction
Worm Gear Reducers

Double Reduction
Worm - Worm Gear Reducers

Double Reduction
Helical - Worm Gear Reducers

WASHGUARD® Reducers
and GEAR+MOTOR™

Ratio Multipliers

Accessories and
Additional Capabilities

NEMA C nput Flange ▲	Style BM			Style HM	Style BMQ			Style HMQ	Ratio
	Left Hand Catalog No	Right Hand Catalog No	Double Extension Catalog No	Hollow Output Catalog No *	Left Hand Catalog No	Right Hand Catalog No	Double Extension Catalog No	Hollow Output Catalog No *	
182 4TC 213 5TC	8300109 8300145	8300121 8300157	8300133 8300169	8300537.XX 8300549.XX	8300253 8300289	8300265 8300301	8300277 8300313	8300585.XX 8300597.XX	5
182 4TC	8300110	8300122	8300134	8300538.XX	8300254	8300266	8300278	8300586.XX	7.5
143 5TC 182 4TC	8300075 8300111	8300087 8300123	8300099 8300135	8300527.XX 8300539.XX	8300219 8300255	8300231 8300267	8300243 8300279	8300575.XX 8300587.XX	10
143 5TC 182 4TC	8300076 8300112	8300088 8300124	8300100 8300136	8300528.XX 8300540.XX	8300220 8300256	8300232 8300268	8300244 8300280	8300576.XX 8300588.XX	15
143 5TC 182 4TC	8300077 8300113	8300089 8300125	8300101 8300137	8300529.XX 8300541.XX	8300221 8300257	8300233 8300269	8300245 8300281	8300577.XX 8300589.XX	20
143 5TC 182 4TC	8300078 8300114	8300090 8300126	8300102 8300138	8300530.XX 8300542.XX	8300222 8300258	8300234 8300270	8300246 8300282	8300578.XX 8300590.XX	25
143 5TC 182 4TC	8300079 8300115	8300091 8300127	8300103 8300139	8300531.XX 8300543.XX	8300223 8300259	8300235 8300271	8300247 8300283	8300579.XX 8300591.XX	30
56C 143 5TC	8300044 8300080	8300056 8300092	8300068 8300104	8300520.XX 8300532.XX	8300188 8300224	8300200 8300236	8300212 8300248	8300568.XX 8300580.XX	40
56C 143 5TC	8300045 8300081	8300057 8300093	8300069 8300105	8300521.XX 8300533.XX	8300189 8300225	8300201 8300237	8300213 8300249	8300569.XX 8300581.XX	50
56C 143 5TC	8300046 8300082	8300058 8300094	8300070 8300106	8300522.XX 8300534.XX	8300190 8300226	8300202 8300238	8300214 8300250	8300570.XX 8300582.XX	60
56C 143 5TC	8300047 8300083	8300059 8300095	8300071 8300107	8300523.XX 8300535.XX	8300191 8300227	8300203 8300239	8300215 8300251	8300571.XX 8300583.XX	80
56C 143 5TC	8300048 8300084	8300060 8300096	8300072 8300108	8300524.XX 8300536.XX	8300192 8300228	8300204 8300240	8300216 8300252	8300572.XX 8300584.XX	100

For input/ output shaft overhung load and thrust load ratings, refer to pages 419-422.

▲ Consult Factory for other motor flanges available.

* Catalog numbers are for hollow output shaft reducers.

When ordering, substitute the XX suffix with the required output bore code.

Available bore codes

Fraction Size	1-3/16"	1-1/4"	1-7/16"	1-1/2"	1-5/8"	1-11/16"	1-3/4"	1-7/8"	1-15/16"	2"	2-3/16"
Decimal Size	1.188	1.250	1.438	1.500	1.625	1.688	1.750	1.875	1.938	2.000	2.188
Output Bore Code	19	20	23	24	26	27	28	30	31	32	35



GR Series Dimensions

Styles: HMQ, HM, H

CAST IRON
GR SERIES

Style HMQ

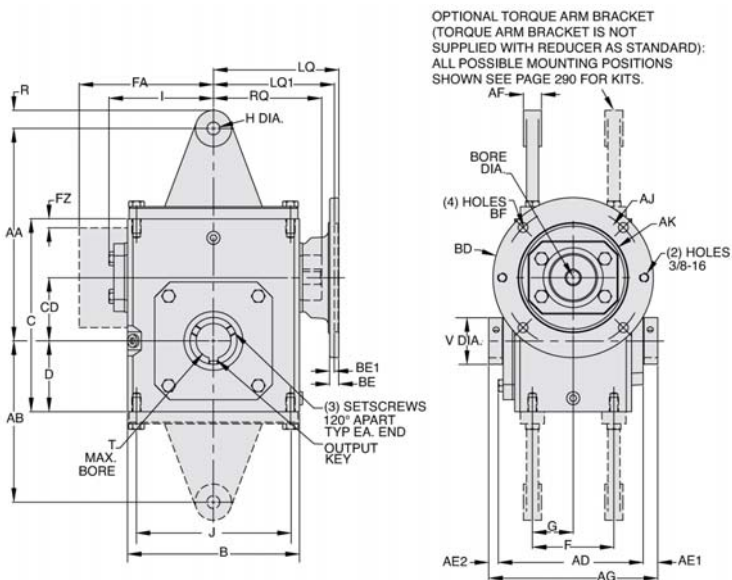

ASSEMBLIES

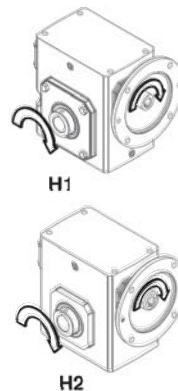

H1 SUPPLIED AS STANDARD UNLESS SPECIFIED.

Style HM

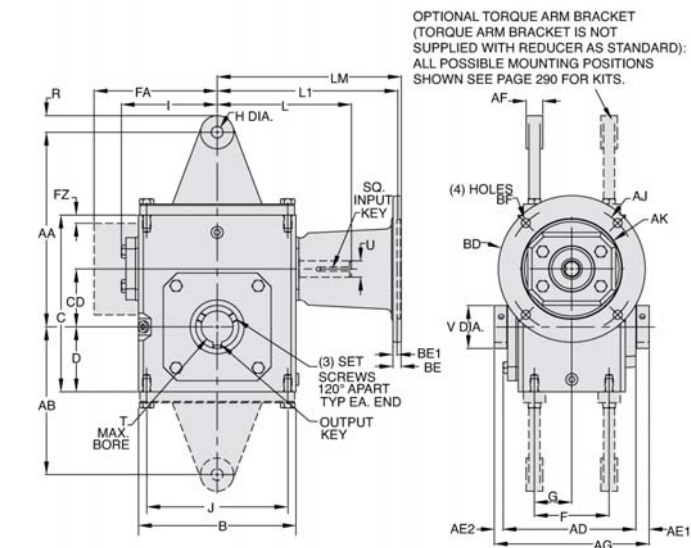

ASSEMBLIES

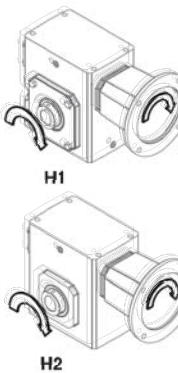

H1 SUPPLIED AS STANDARD UNLESS SPECIFIED.

Style H

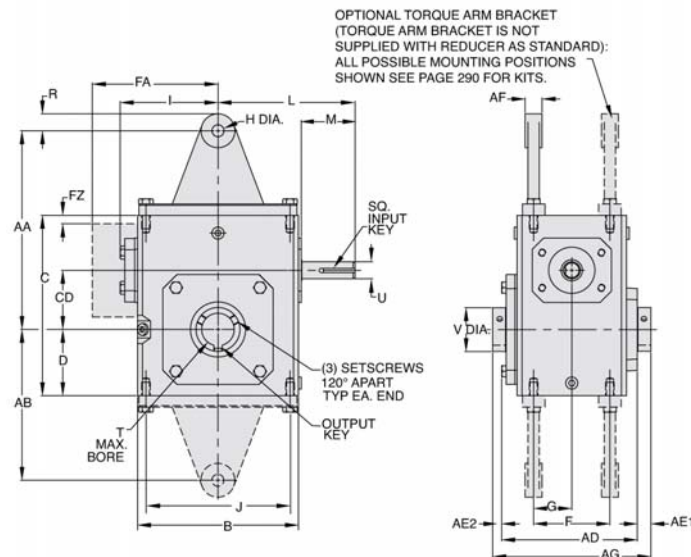

ASSEMBLIES

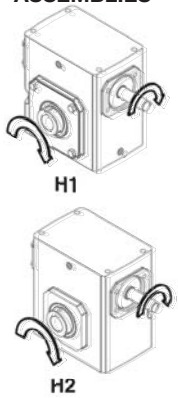

REVERSE ALL ARROWS FOR OPPOSITE INPUT SHAFT ROTATION. CONTACT FACTORY FOR OTHER MOUNTINGS OR ASSEMBLY POSITIONS.

H1 SUPPLIED AS STANDARD UNLESS SPECIFIED.

Single Reduction
Worm Gear Reducers

Double Reduction
Worm - Worm Gear Reducers

Double Reduction
Helical - Worm Gear Reducers

WASHGUARD® Reducers
and GEAR+MOTOR™

Ratio Multipliers

Accessories and
Additional Capabilities



STYLE HMQ, HM, H DIMENSIONS (Inches)

Series	AD	AE1	AE2	AG	B	C	D	CD	F	FA▼	FZ▼	G	I	J	L	M	V	T MAX -0.000 +0.0025	U +0.000 -0.0015	Input Key*	Output Key +
GR813	3.90	0.53	0.32	4.75	3.80	4.66	1.72	1.33	2.00	N/A	N/A	1.00	2.61	3.25	3.82	1.76	1.000	0.625	0.500	1/8 x 1.00	3/16 x 1.50
GR815	4.61	0.51	0.30	5.42	5.19	5.38	1.91	1.54	2.75	N/A	N/A	1.38	3.14	4.19	4.35	1.76	1.000	0.625	0.625	3/16 x 1.38	3/16 x 1.50
GR818	4.73	0.49	0.28	5.50	5.19	5.75	2.06	1.75	2.75	N/A	N/A	1.38	3.24	4.19	4.45	1.76	1.440	1.000	0.625	3/16 x 1.38	1/4 x 3.00
GR821	4.99	0.61	0.40	6.00	5.80	6.38	2.28	2.06	▲	N/A	N/A	1.44	3.61	▲	4.82	1.76	1.940	1.500	0.625	3/16 x 1.38	3/8 x 3.00
GR824	5.18	0.51	0.31	6.00	6.12	6.94	2.50	2.38	2.88	N/A	N/A	1.44	3.77	5.00	5.51	2.38	1.940	1.500	0.750	3/16 x 1.63	3/8 x 3.00
GR826x	6.01	0.60	0.39	7.00	7.38	8.00	2.94	2.63	3.38	N/A	N/A	1.69	4.34	6.38	6.07	2.38	1.940	1.500	0.750	3/16 x 1.63	3/8 x 3.00
GR830	6.53	0.60	0.36	7.50	8.12	8.88	3.25	3.00	4.00	N/A	N/A	2.00	4.84	7.00	6.57	2.38	2.756	2.188	0.875	3/16 x 1.63	1/2 x 3.00
GR832x	7.04	0.54	0.29	7.88	8.75	9.38	3.50	3.25	4.00	N/A	N/A	2.00	5.02	7.50	6.76	2.38	2.756	2.188	0.875	3/16 x 1.63	1/2 x 3.00
GR842	7.53	0.63	0.34	8.50	10.25	11.38	4.44	4.25	5.00	N/A	N/A	2.50	6.10	8.50	9.57	3.47	2.756	2.188	1.250	1/4 x 2.50	1/2 x 3.00
GR852	8.85	0.97	0.68	10.50	13.00	14.00	5.12	5.25	5.81	N/A	N/A	2.91	7.50	11.00	10.88	3.38	4.260	3.438	1.250	1/4 x3.00	7/8 x3.44
GR860	10.52	0.52	0.52	11.50	14.50	16.50	6.50	6.00	6.38	11.13	0.33	3.19	N/A	12.75	11.78	3.41	4.256	3.438	1.500	3/8 x 3.00	7/8 x 3.44
GR870	11.36	1.09	1.09	13.50	14.88	18.91	7.59	7.00	5.50	11.37	0.35	2.75	N/A	12.50	11.50	2.97	4.928	3.938	1.625	3/8 x 2.87**	1 x 1/2**
GR880	12.48	1.03	1.03	14.50	17.00	20.96	8.86	8.00	6.50	12.52	0.57	3.25	N/A	14.25	12.50	2.84	5.553	4.438	1.875	1/2 x 2.81**	1 x 1/2**
GR8100	15.78	1.39	1.39	18.50	20.88	25.47	10.36	10.00	6.88	14.69	0.51	3.44	N/A	14.75	15.50	3.76	4.256	5.438	2.250	1/2 x 3.69**	1-1/4 x 5/8**

▲ See feature comparison chart.

FEATURE COMPARISON (821)

Size	Output Shaft Diameter Needed?	Mounting Footprint Needed?	Output Key Needed?	All Other Features	Grove Gear Flexaline Interchange	LEESON IRONMAN Interchange	Replace With Series Code Below:
GR821	Identical	(F)3.00" x (J)4.75" (F)2.88" x (J)5.00"	Identical	Identical	✓	✓	GRG GRL

NOTE: If reducer is used without the accessory mounted, select based mounting dimensions on pages 52-53 (B, BM, BMQ).

**Motor Mounting Dimensions
NEMA DIMENSIONS (Inches)**

Size	48CZ LM	56C/140TC	180TC/210TC	L1 250TC	LQ 48CZ/56C/140TC	180TC	LQ1 210TC	250TC	48CZ/56C/140TC	180TC	RQ 210TC	250TC
GR813	5.63	6.07	N/A	N/A	3.46	N/A	N/A	N/A	3.09	N/A	N/A	N/A
GR815	6.16	6.60	N/A	N/A	3.99	N/A	N/A	N/A	3.62	N/A	N/A	N/A
GR818	6.26	6.70	N/A	N/A	4.09	N/A	N/A	N/A	3.59	N/A	N/A	N/A
GR821*	6.63	7.07	N/A	N/A	4.46	N/A	N/A	N/A	4.06	N/A	N/A	N/A
GR824	N/A	7.76	8.76	N/A	4.63■	5.06	N/A	N/A	4.09■	4.56	N/A	N/A
GR826*	N/A	8.32	9.32	N/A	5.19■	5.62	N/A	N/A	4.82■	5.13	N/A	N/A
GR830	N/A	8.82	9.82	N/A	5.95■	6.15	6.56	N/A	5.32■	5.63	6.06	N/A
GR832*	N/A	9.01	10.01	N/A	6.14■	6.34	6.75	N/A	5.51■	5.81	6.25	N/A
GR842	N/A	11.81	12.90	13.46	6.45■	7.21	7.21	7.77	6.04■	6.68	6.68	7.24
GR852	N/A	13.21	14.30	14.86	7.85■	8.61	8.61	9.17	7.35■	7.98	7.98	8.54
GR860	N/A	N/A	15.88	16.50	10.45■	9.33	9.33	9.94	10.01■	8.69	8.69	8.69
GR870	N/A	N/A	15.50	15.50	N/A	N/A	N/A	N/A	N/A	N/A	N/A	N/A
GR880	N/A	N/A	16.58●	16.58	N/A	N/A	N/A	N/A	N/A	N/A	N/A	N/A

NEMA DIMENSIONS (Inches)

Frame	AJb	AK	BD	BE	BE1	Bore Dia.	Keyway◆	BFb
	3.75	3.00	4.36	0.38	N/A	.500	1/8 X 1/16	0.28
56C	5.88	4.50	6.50	0.38	N/A	.625	3/16 X 3/32	0.41
140TC	5.88	4.50	6.50	0.38	N/A	.875	3/16 X 3/32	0.41
180TC	7.25	8.50	9.00	N/A	0.50	1.125	1/4 X 1/8	0.53
210TC	7.25	8.50	9.00	N/A	0.50	1.375	5/16 X 5/32	0.53
250TC	7.25	8.50	9.00	N/A	0.50	1.625	3/8 X 3/16	0.53

IEC B5 & B3/B5 METRIC DIMENSIONS (Inches)◆

Size	LQ1						RQ					
	D63D	D71D	D80D	D90D	D100LD/D112MD	D132D	D63D	D71D	D80D	D90D	D100LD/D112MD	D132D
GR813	2.62	2.65	2.89	N/A	N/A	N/A	2.45	2.47	2.71	N/A	N/A	N/A
GR815	3.15	3.18	3.42	N/A	N/A	N/A	2.98	3.00	3.24	N/A	N/A	N/A
GR818	3.25	3.28	3.52	N/A	N/A	N/A	2.95	2.97	3.21	N/A	N/A	N/A
GR821*	3.62	3.65	3.89	N/A	N/A	N/A	3.43	3.44	3.68	N/A	N/A	N/A
GR824	N/A	3.72	4.34	N/A	N/A	N/A	3.46	3.71	N/A	N/A	N/A	N/A
GR826*	N/A	4.28	4.90	4.90	5.30	N/A	N/A	4.09	4.72	4.72	5.07	N/A
GR830	N/A	4.78	5.41	5.41	5.88	N/A	N/A	4.59	5.22	5.22	5.57	N/A
GR832*	N/A	4.97	5.59	5.59	6.07	N/A	N/A	4.78	5.41	5.41	5.76	N/A
GR842	N/A	N/A	N/A	6.38	6.39	7.17	N/A	N/A	N/A	6.16	6.14	6.93
GR852	N/A	N/A	N/A	7.78	7.78	8.57	N/A	N/A	N/A	7.46	7.45	8.24

IEC B5 & B3/B5 METRIC DIMENSIONS (MM)

Frame	AJ	AK	BD	BE	Bore Dia.	Keyway◆	BF TAP	OD
D63D	115	95	117	10	11	4 X 2	M8 X 1.25	131
D71D	130	110	132	11	14	5 X 2.5	M8 X 1.25	146
D80D	165	130	165	15	19	6 X 3	M10 X 1.50	184
D90D	165	130	165	15	24	8 X 3.5	M10 X 1.50	184
D100LD/D112MD	215	180	216	18	28	8 X 3.5	M12 X 1.75	237
D132D	265	230	267	18	38	10 X 4	M12 X 1.75	290

◆ Max bore dimensions shown. For additional bores available, refer to page 20.

* Applies to double output shaft

** Key not provided with gear reducer. Keyway dimension shown.

◆ Keyway width by depth

◆ Mounting holes rotated 45 degrees from positions shown on Size GR860, Style HM with frame sizes 180TC-250TC.

■ 48CZ not available

● 180TC not available

◆ Metric IEC B5 input flange options are available only on quill input styles.

* Dimensions same for GRG and GRL Series

* Style H and HM only.

▼ Sizes 860-8100 are supplied with a fan. Dimensions refer to fan guard location.

Note: Torque arm bracket available separately. Refer to page 274 for kits. If a special bracket is required, refer to Style BMQ dimensions for mounting pad dimensions on top/bottom of reducer.



For safety, purchaser or user should provide protective guards over shaft extensions and any couplings, sheaves and belts, sprockets and chains, etc., mounted thereon.

Single Reduction
Worm Gear Reducers

Double Reduction
Worm - Worm Gear Reducers

Double Reduction
Helical - Worm Gear Reducers

WASHGARD® Reducers
and GEAR-HMOTOR™

Ratio Multipliers

Accessories and
Additional Capabilities